

ÜBERSICHTSZEICHNUNG
ASSEMBLY DRAWING

LAPIERRE



OVERVOLT AM 9.7 / 8.7 / 7.7 / 6.7 / 5.6 (MY23)

OVERVOLT TR 6.7 / 5.7 / 4.6 (MY23)

E-EXPLORER FS 9.7 / 8.6 (MY23)

OVERVOLT AM 9.7 / AM 8.7 / AM 7.7 / AM 6.7 / AM 5.6 / TR 6.7 / TR 5.7 / TR 4.6 / E-EXPLORER FS 9.7 / 8.6 (MY23)

date: 22-06-2023

version: 01



ÜBERSICHTSZEICHNUNG

ASSEMBLY DRAWING front triangle

LAPIERRE

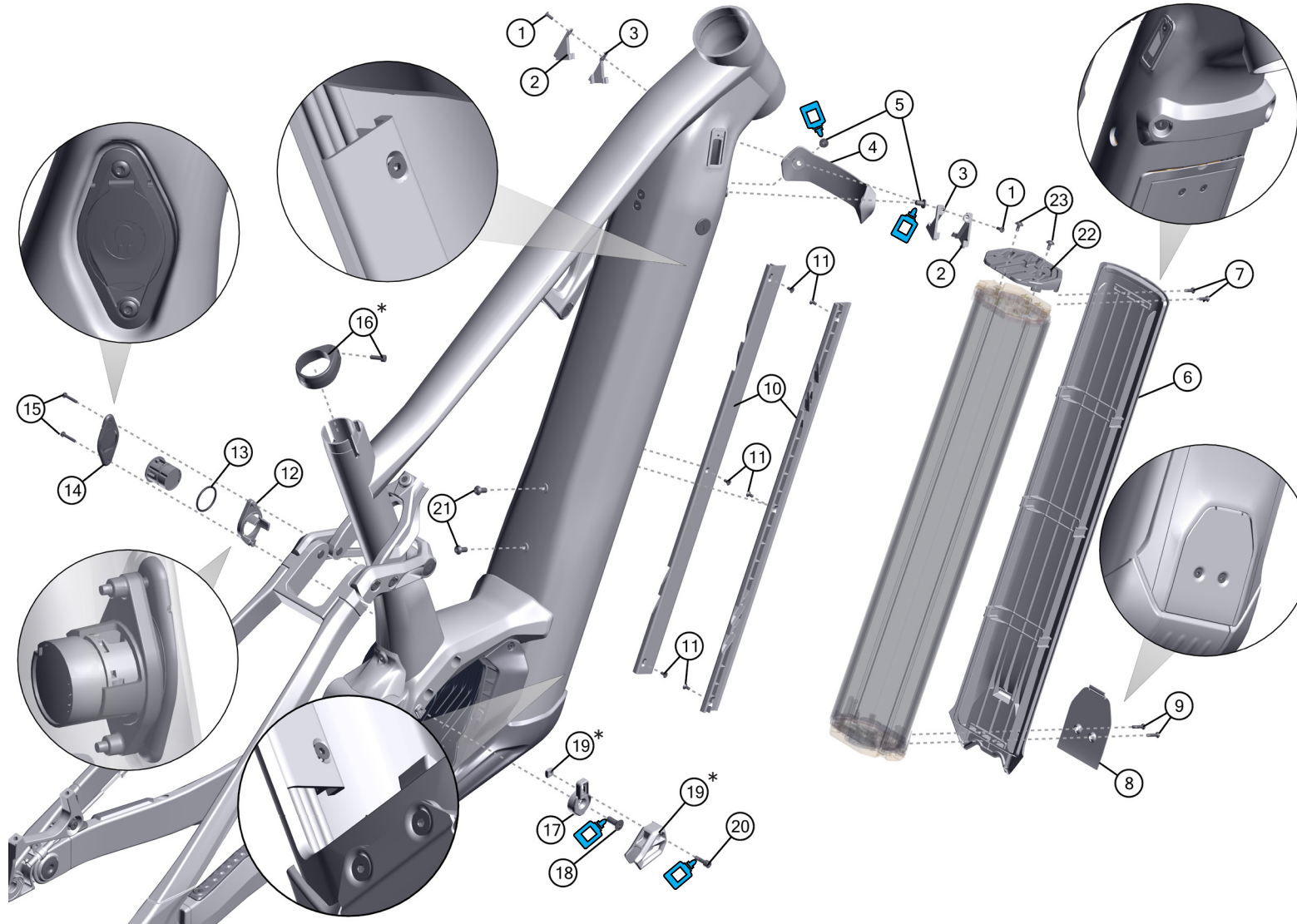

Hinweis: Bei den Schrauben muss mittelfeste Gewindesicherung verwendet werden. Rote Flächen müssen gefettet werden.

Note: use medium strength screw lock for screw threads. red surfaces has to be greased.



➤ medium strength screwlock

OVERVOLT AM 9.7 / AM 8.7 / AM 7.7 / AM 6.7 / AM 5.6 / TR 6.7 / TR 5.7 / TR 4.6 / E-EXPLORER FS 9.7 / 8.6 (MY23)

date: 22-06-2023

version: 01



ÜBERSICHTSZEICHNUNG

ASSEMBLY DRAWING front triangle

LAPIERRE

BOM-ID	Description	Specification	Torque	Item no.	QTY
1	Counter sunk screw	IS2 - M3 x 6 mm	1 Nm	FRSC0136	2
2	Cable inlets left side			FROT0170	2
3	Cable inlets right side			FROT0169	2
4	Fork bumper			FRPR0084	1
5	Lens head screw	IS3 - M5 x 8 mm	2 Nm	FRSC0102	2
6	Battery cover			COV0012	1
7	Counter sunk screw	IS2 - M3 x 12 mm	1 Nm	FRSC0137	2
8	Battery metal skidplate			FROT0230	1
9	Counter sunk screw (stainless steel)	IS2 - M3 x 16 mm	1 Nm	FRSC0156	2
10	Cable guide			RAI0002	2
11	Counter sunk screw	IS2.5 - M4 x 6 mm	1 Nm	FRSC0153	6
12	Charge port frame			FROT0212	1
13	O-ring charge port			ELOT0007	1
14	Charge port cover			FROT0097	1
15	Lens head screw	TX10 - M3 x 16 mm	1 Nm	FRSC0143	2
16*	Seatclamp (set incl. screw)	Ø 34,9 mm		SC0008	1
16*	Cylinder head screw (set incl. seatclamp)	IS4 - M5 x 12 mm	6 Nm	SC0008	1
17	Chain guide bracket			FROT0235	1
18	Lens head screw (stainless steel)	IS4 - M6 x 10 mm	5 Nm	FRSC0157	1
19*	Chain guide (set incl. screw and nut)			CG0022	1
19*	Square nut (set incl. chain guide and screw)	M4		CG0022	1
20	Cylinder head screw (flat head)	IS2.5 - M4 x 16 mm	3 Nm	FRSC0203	1
21	Lens head screw	TX25 - M5 x 6 mm	6 Nm	SM1673	2
22	Screw-on plate			FRSC0124	1
23	Screw for screw-on plate	TX15 - M3 x 7 mm	1.2 Nm	FRSC0123	2

OVERVOLT AM 9.7 / AM 8.7 / AM 7.7 / AM 6.7 / AM 5.6 / TR 6.7 / TR 5.7 / TR 4.6 / E-EXPLORER FS 9.7 / 8.6 (MY23)

date: 22-06-2023

version: 01



ÜBERSICHTSZEICHNUNG

ASSEMBLY DRAWING battery mount

LAPIERRE

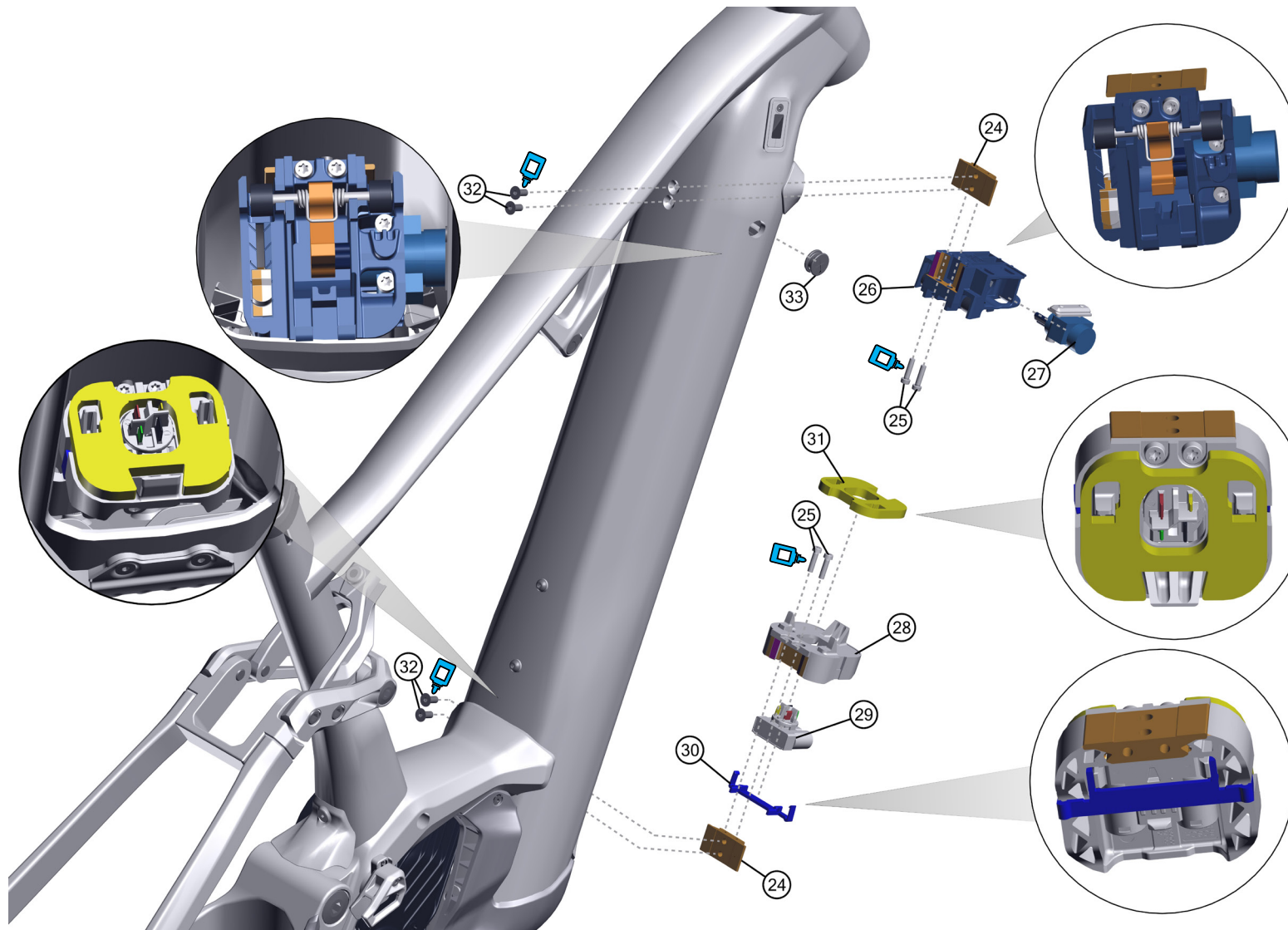

Hinweis: Bei den Schrauben muss mittelfeste Gewindesicherung verwendet werden. Rote Flächen müssen gefettet werden.

Note: use medium strength screw lock for screw threads. red surfaces has to be greased.



➤ medium strength screwlock

OVERVOLT AM 9.7 / AM 8.7 / AM 7.7 / AM 6.7 / AM 5.6 / TR 6.7 / TR 5.7 / TR 4.6 / E-EXPLORER FS 9.7 / 8.6 (MY23)

date: 22-06-2023

version: 01



ÜBERSICHTSZEICHNUNG

ASSEMBLY DRAWING battery mount

LAPIERRE

BOM-ID	Description	Specification	Torque	Item no.	QTY
24	Battery holder adapter			FROT0234	2
25	Screw for battery holder adapter	TX20 - M4 x 16 mm	3 Nm	FRSC0121	4
26	Locking assembly			LO0006	1
27	Battery lock	IT3 XPLUS		LO0007	1
28	Cradle			ELOT0003	1
29	Battery adapter			ELOT0006	1
30	Clamp ring			ELOT0008	1
31	Damper foil poron plug			ELOT0005	1
32	Counter sunk screw	IS3 - M5 x 12 mm	6 Nm	FRSC0141	4
33	Rubber ring			FROT0215	1



OVERVOLT AM 9.7 / AM 8.7 / AM 7.7 / AM 6.7 / AM 5.6 / TR 6.7 / TR 5.7 / TR 4.6 / E-EXPLORER FS 9.7 / 8.6 (MY23)

date: 22-06-2023

version: 01

ÜBERSICHTSZEICHNUNG

ASSEMBLY DRAWING

motor cover

LAPIERRE

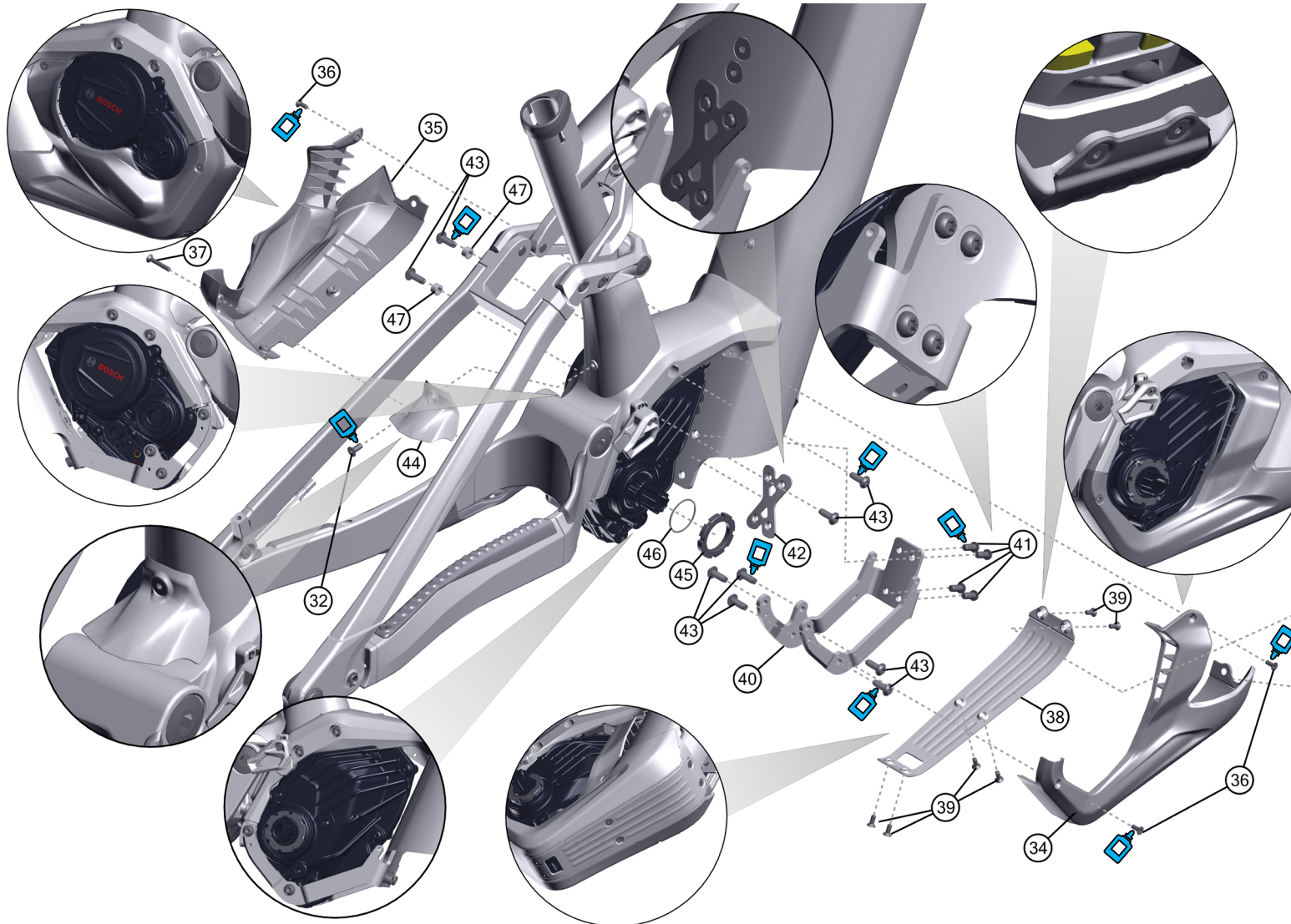

Hinweis: Bei den Schrauben muss mittelfeste Gewindesicherung verwendet werden. Rote Flächen müssen gefettet werden.

Note: use medium strength screw lock for screw threads. red surfaces has to be greased.



➤ medium strength screwlock

OVERVOLT AM 9.7 / AM 8.7 / AM 7.7 / AM 6.7 / AM 5.6 / TR 6.7 / TR 5.7 / TR 4.6 / E-EXPLORER FS 9.7 / 8.6 (MY23)

date: 22-06-2023

version: 01



ÜBERSICHTSZEICHNUNG

ASSEMBLY DRAWING motor cover

LAPIERRE

BOM-ID	Description	Specification	Torque	Item no.	QTY
32	Counter sunk screw	IS3 - M5 x 12 mm	2 Nm	FRSC0141	1
34	Motor cover right			COV0011	1
35	Motor cover left			COV0010	1
36	Counter sunk screw	IS2.5 - M4 x 12 mm	2 Nm	FRSC0138	3
37	Counter sunk screw	IS2.5 - M4 x 25 mm	2 Nm	FRSC0139	1
38	Motor metal skidplate			FROT0229	1
39	Counter sunk screw (stainless steel)	IS2.5 - M4 x 10 mm	2 Nm	FRSC0155	6
40	Motor bracket			FROT0231	1
41	Lens head screw	TX30 - M6 x 12 mm	11 Nm	FRSC0204	4
42	Motor bracket Xplate			FROT0232	1
43	Screw for mounting connection plate	TX30 - M6 x 16 mm	10 Nm	FRSC0125	9
44	Mudguard			FRPR0081	1
45	Lockring for BDU4XX			FROT0180	1
46	O-Ring			FROT0181	1
47	Motor bushing			FROT0233	2
47	Motor bushing			FROT0233	2



OVERVOLT AM 9.7 / AM 8.7 / AM 7.7 / AM 6.7 / AM 5.6 / TR 6.7 / TR 5.7 / TR 4.6 / E-EXPLORER FS 9.7 / 8.6 (MY23)

date: 22-06-2023

version: 01

ÜBERSICHTSZEICHNUNG ASSEMBLY DRAWING

rocker

LAPIERRE

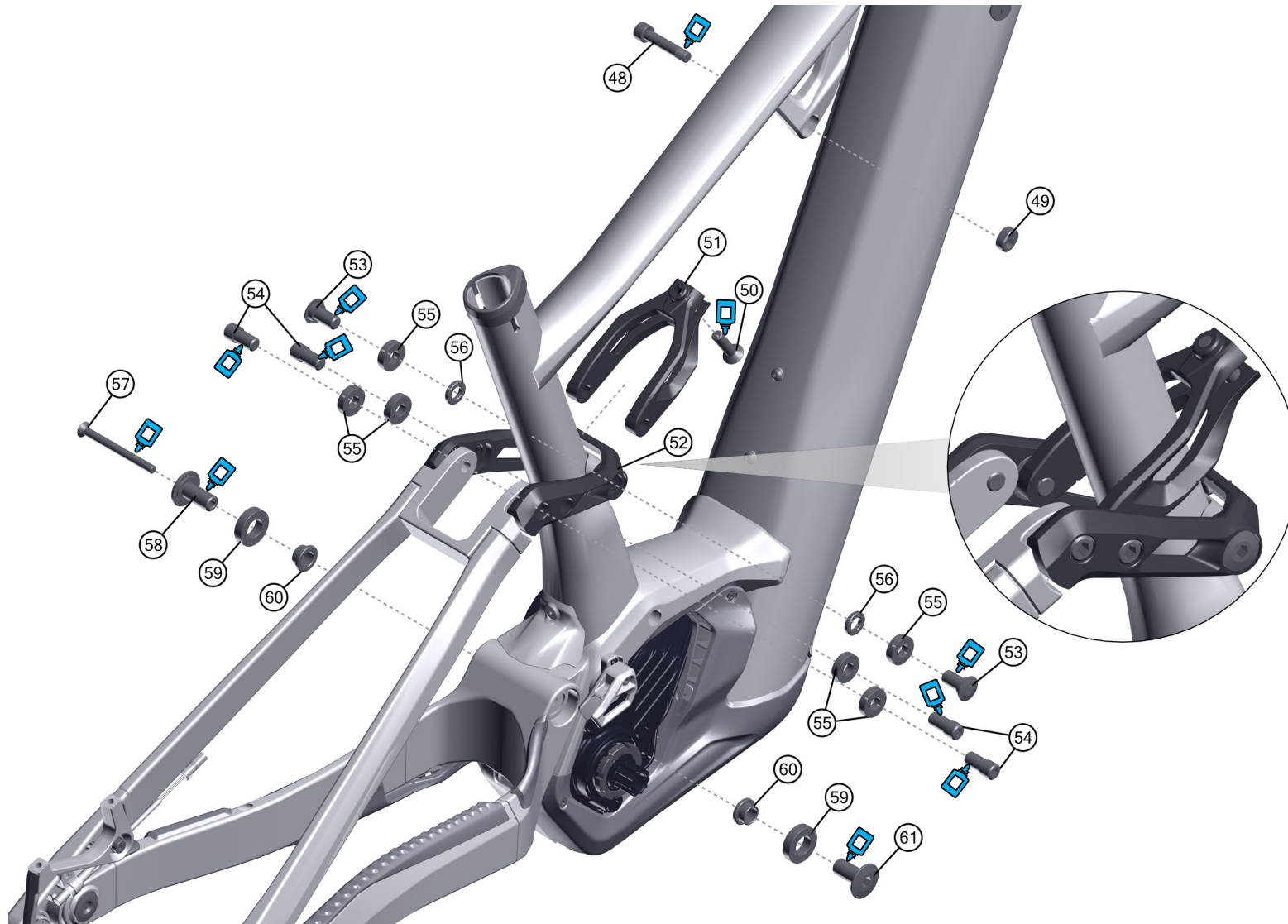

Hinweis: Bei den Schrauben muss mittelfeste Gewindesicherung verwendet werden. Rote Flächen müssen gefettet werden.

Note: use medium strength screw lock for screw threads. red surfaces has to be greased.



➤ medium strength screwlock

OVERVOLT AM 9.7 / AM 8.7 / AM 7.7 / AM 6.7 / AM 5.6 / TR 6.7 / TR 5.7 / TR 4.6 / E-EXPLORER FS 9.7 / 8.6 (MY23)

date: 22-06-2023

version: 01



ÜBERSICHTSZEICHNUNG

ASSEMBLY DRAWING **rocker**

LAPIERRE

BOM-ID	Description	Specification	Torque	Item no.	QTY
48	Shockmount screw (cylinder head)	IS6 - M8 x 40 mm	10 Nm	FRSC0171	1
49	Shockmount nut	M8		FRNT0055	1
50	Shock-link-top screw (counter sunk)	IS5 - M8 x 30 mm	10 Nm	FRSC0172	1
51	Rocker link-top			FRRO0005	1
52	Rocker link			FRRO0006	1
53	Link-top screw	IS6 - M10 x 17.5 mm	14 - 18 Nm	FROT0125	2
54	Link screw	IS6 - M10 x 17 mm	14 - 18 Nm	FROT0126	4
55	Link bearing	S&S 6900-2RS 22x10x6 mm		FROT0119	6
56	Link-top spacer	Ø 18 x 10.1 x 3.5 mm		FRSP0005	2
57	Main pivot locking screw (counter sunk)	IS4 - M6 x 70 mm	6 Nm	FRSC0173	1
58	Main pivot screw left	IS8 - M12 x 25 mm	18 - 20 Nm	FRSC0174	1
59	Main pivot bearing	S&S 6902-2RS 28x15x7 mm		FROT0128	2
60	Main pivot bushing	Ø 14.98 x 12 x 3 mm		FROT0258	2
61	Main pivot screw right	IS8 - M12 x 25 mm	18 - 20 Nm	FRSC0175	1



OVERVOLT AM 9.7 / AM 8.7 / AM 7.7 / AM 6.7 / AM 5.6 / TR 6.7 / TR 5.7 / TR 4.6 / E-EXPLORER FS 9.7 / 8.6 (MY23)

date: 22-06-2023

version: 01

ÜBERSICHTSZEICHNUNG

ASSEMBLY DRAWING rear triangle

LAPIERRE

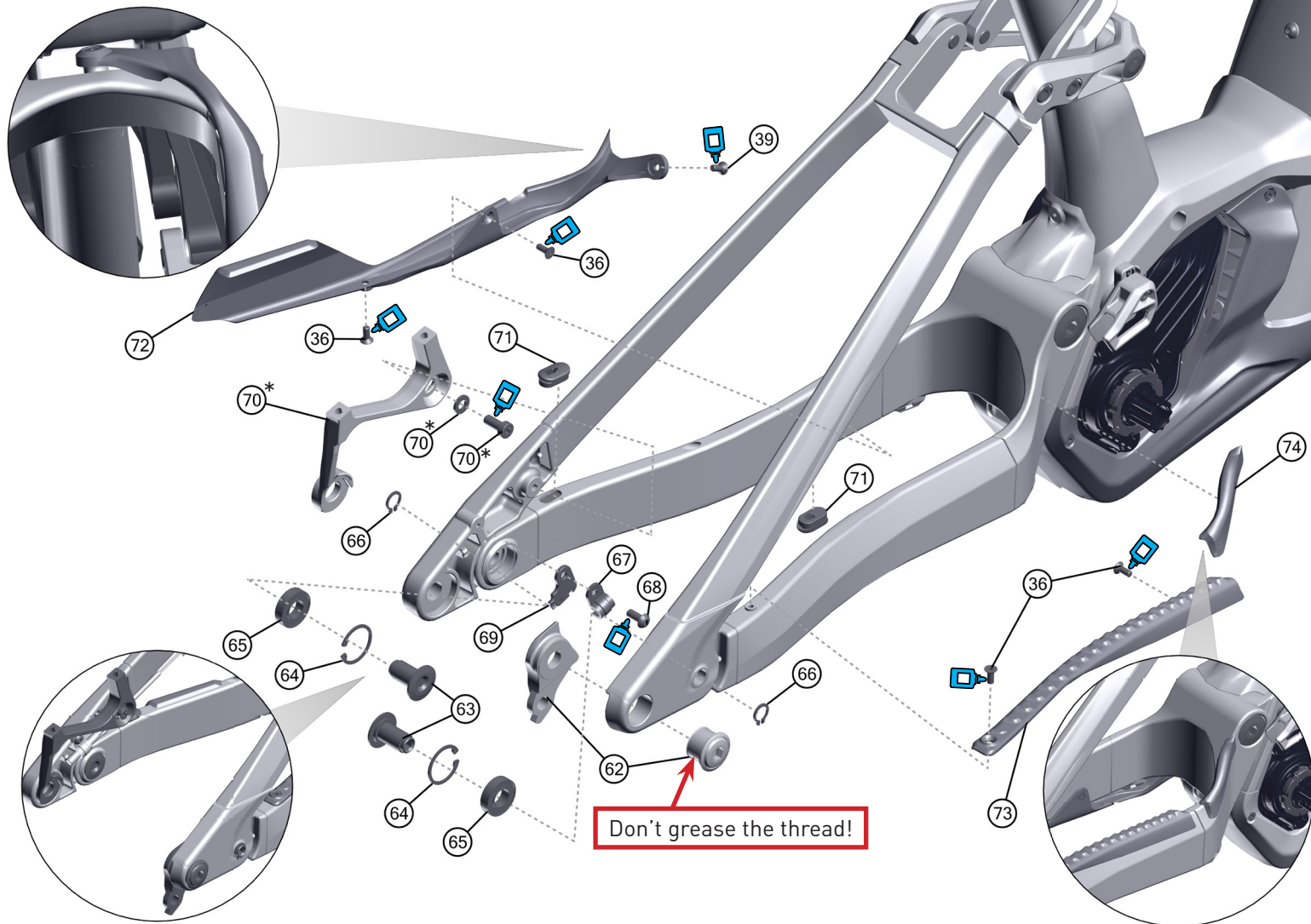

Hinweis: Bei den Schrauben muss mittelfeste Gewindesicherung verwendet werden. Rote Flächen müssen gefettet werden.

Note: use medium strength screw lock for screw threads. red surfaces has to be greased.



➤ medium strength screwlock

OVERVOLT AM 9.7 / AM 8.7 / AM 7.7 / AM 6.7 / AM 5.6 / TR 6.7 / TR 5.7 / TR 4.6 / E-EXPLORER FS 9.7 / 8.6 (MY23)

date: 22-06-2023

version: 01



ÜBERSICHTSZEICHNUNG

ASSEMBLY DRAWING rear triangle

LAPIERRE

BOM-ID	Description	Specification	Torque	Item no.	QTY
36	Counter sunk screw	IS2.5 - M4 x 12 mm	1 Nm	FRSC0138	4
39	Counter sunk screw (stainless steel)	IS2.5 - M4 x 10 mm	1 Nm	FRSC0155	1
62	UDH derailleur hanger + nut	Don't grease the thread!	25 Nm	FRHG0061	1
63	Chainstay screw	IS6 - M12 x 20.8 mm	14 - 18 Nm	FROT0141	2
64	Bearing circlip	Ø 24 mm		FRWS0048	2
65	Chainstay bearing	S&S 6901-2RS 24x12x6 mm		FROT0136	2
66	Screw circlip	Ø 10 mm		FRWS0049	2
67	Clip holder			EL0276	1
68	Screw		1 Nm	EL0277	1
69	Speed sensor spacer (SHIMANO rotor only)			ELOT0011	1
70*	Rear brake mount adapter (set incl. screw and washer)			FROT0171	1
70*	Cylinder head screw (set incl. rear brake mount adapter and washer)	IS5 - M6 x 16 mm	11 Nm	FROT0171	1
70*	Washer (set incl. rear brake mount adapter and screw)	Ø 6,4 mm		FROT0171	1
71	Cable rubber	SW415		FROT0154	2
72	Chainstay protector left side			FRPR0082	1
73	Chainstay protector right side rear			FRPR0083	1
74	Chainstay protector right side front			FRPR0080	1

OVERVOLT AM 9.7 / AM 8.7 / AM 7.7 / AM 6.7 / AM 5.6 / TR 6.7 / TR 5.7 / TR 4.6 / E-EXPLORER FS 9.7 / 8.6 (MY23)

date: 22-06-2023

version: 01



ÜBERSICHTSZEICHNUNG

ASSEMBLY DRAWING bearing kit

LAPIERRE

BOM-ID	Description	Specification	Torque	Item no.	QTY
	Bearing kit			KE0343	1
55	Link bearing	S&S 6900-2RS 22x10x6 mm		FROT0119	6
56	Link-top spacer	Ø 18 x 10.1 x 3.5 mm		FRSP0005	2
59	Main pivot bearing	S&S 6902-2RS 28x15x7 mm		FROT0128	2
60	Main pivot bushings	Ø 14.98 x 12 x 3 mm		FROT0258	2
65	Chainstay bearing	S&S 6901-2RS 24x12x6 mm		FROT0136	2

Item no. bearing kit: **KE0343**

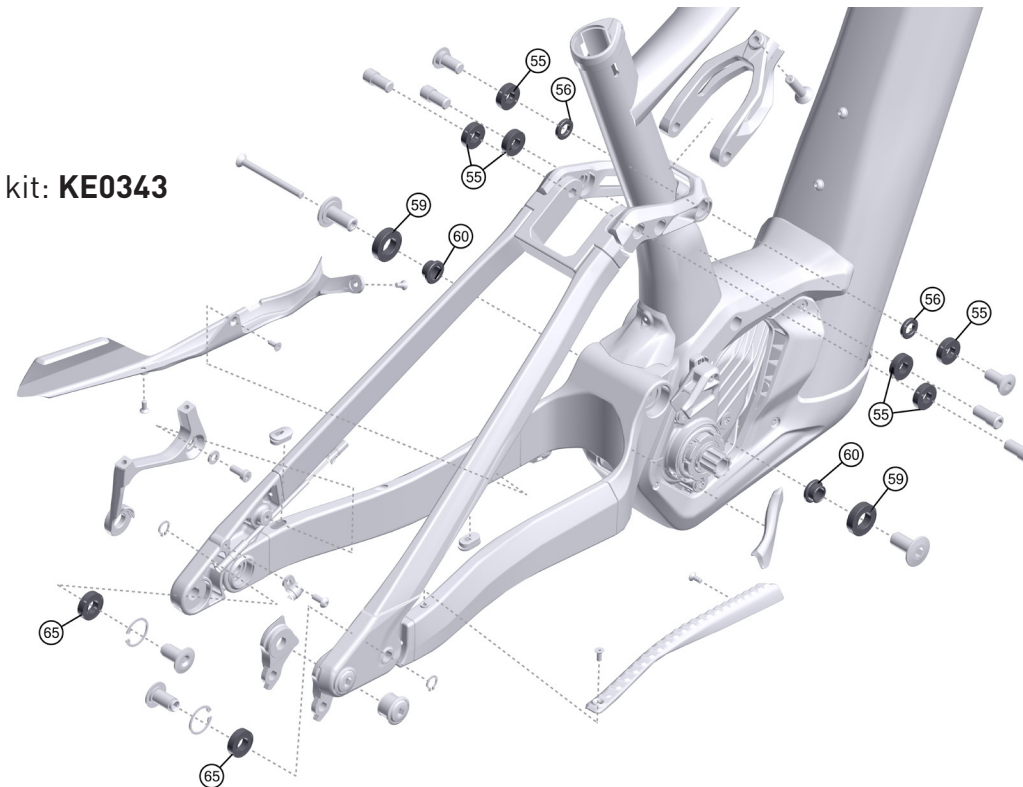

OVERVOLT AM 9.7 / AM 8.7 / AM 7.7 / AM 6.7 / AM 5.6 / TR 6.7 / TR 5.7 / TR 4.6 / E-EXPLORER FS 9.7 / 8.6 (MY23)

date: 22-06-2023

version: 01



ÜBERSICHTSZEICHNUNG

ASSEMBLY DRAWING rear shock screw kit

LAPIERRE

BOM-ID	Description	Specification	Torque	Item no.	QTY
	Rear shock screw kit			KE0344	1
48	Shockmount screw (cylinder head)	IS6 - M8 x 40 mm	10 Nm	FRSC0171	1
49	Shockmount nut	M8		FRNT0055	1
50	Shock-link-top screw (counter sunk)	IS5 - M8 x 30 mm	10 Nm	FRSC0172	1

Item no. rear shock screw kit: **KE0344**

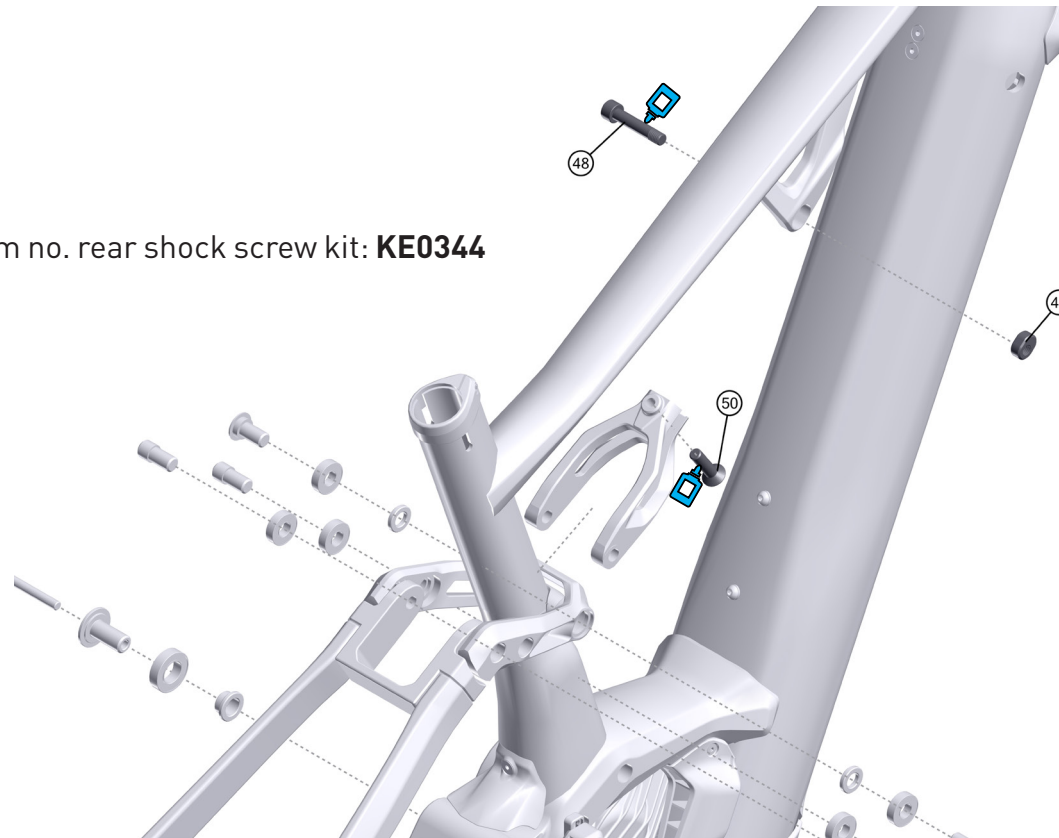

OVERVOLT AM 9.7 / AM 8.7 / AM 7.7 / AM 6.7 / AM 5.6 / TR 6.7 / TR 5.7 / TR 4.6 / E-EXPLORER FS 9.7 / 8.6 (MY23)

date: 22-06-2023

version: 01



ÜBERSICHTSZEICHNUNG

ASSEMBLY DRAWING axle & screw kit

LAPIERRE

BOM-ID	Description	Specification	Torque	Item no.	QTY
	Axle & screw kit			KE0345	1
53	Link-top screw	IS6 - M10 x 17.5 mm	14 - 18 Nm	FROT0125	2
54	Link screw	IS6 - M10 x 17 mm	14 - 18 Nm	FROT0126	4
57	Main pivot locking screw (counter sunk)	IS4 - M6 x 70 mm	6 Nm	FRSC0173	1
58	Main pivot screw left	IS8 - M12 x 25 mm	18 - 20 Nm	FRSC0174	1
61	Main pivot screw right	IS8 - M12 x 25 mm	18 - 20 Nm	FRSC0175	1
63	Chainstay screw	IS6 - M12 x 20.8 mm	14 - 18 Nm	FROT0141	2

Item no. axle and screw kit: **KE0345**

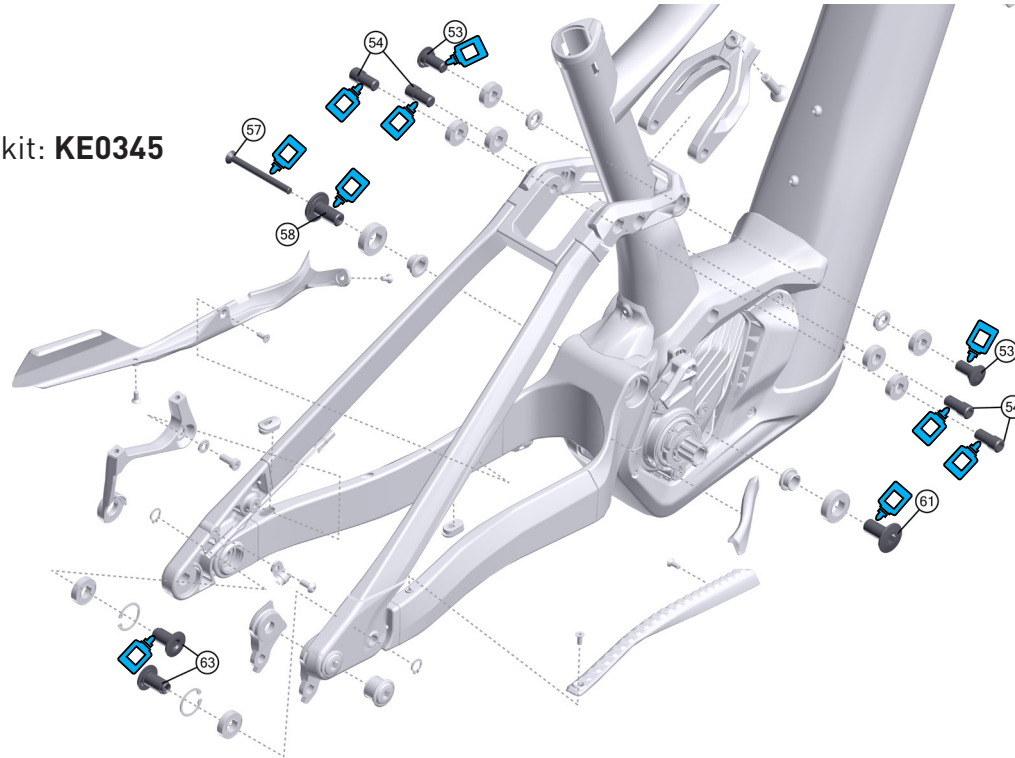

OVERVOLT AM 9.7 / AM 8.7 / AM 7.7 / AM 6.7 / AM 5.6 / TR 6.7 / TR 5.7 / TR 4.6 / E-EXPLORER FS 9.7 / 8.6 (MY23)

date: 22-06-2023

version: 01



ÜBERSICHTSZEICHNUNG

ASSEMBLY DRAWING

LAPIERRE

FACT SHEET:	
SHOCK LENGTH:	OVERVOLT AM: 230 MM OVERVOLT TR: 210 MM
SHOCK HARDWARE TOP:	25 MM x M8
SHOCK HARDWARE BOTTOM:	15 MM x M8
HEADSET TOP:	ZS 56
HEADSET BOTTOM:	ZS 56
SEATPOST DIAMETER:	31,6 MM
CLAMP INNER DIAMETER:	34,9 MM
BOTTOM BRACKET:	-----
KICKSTAND:	-----
ISCG STANDARD:	-----
CARRIER MOUNT:	NO
FENDER COMPATIBLE:	NO

DROPPER SEATPOST READY:	YES
WATTERBOTTLE MOUNT:	1x 0,5 L
MAXIMUM PERMISSIBLE TOTAL WEIGHT:	120 KG
MAXIMUM TIRE SIZE:	
WHEEL SIZE:	OVERVOLT AM: 29" / 27,5" OVERVOLT TR / E-EXPLORER FS: Size S 27,5" Size M / L / XL 29"
QUICK RELEASE LENGTH:	180 MM
OVER-LOCKNUT DIMENSION (O.L.D.):	148 MM
FD CLAMP SIZE:	-----
FD TYPE:	-----
ENGINE:	BOSCH PERFORMANCE LINE CX
BATTERY:	BOSCH POWERTUBE 750 WH
DISPLAY:	BOSCH LED REMOTE BOSCH KIOX 300



OVERVOLT AM 9.7 / AM 8.7 / AM 7.7 / AM 6.7 / AM 5.6 / TR 6.7 / TR 5.7 / TR 4.6 / E-EXPLORER FS 9.7 / 8.6 (MY23)

date: 22-06-2023

version: 01